

Cassette ceiling(4-way flow)

PLFY-P-VKM-A
PLFY-P-VAM-A

CONTENTS

1. Specifications	388
2. Capacity Tables	389
2-1 Cooling capacity(Y-5HP)	389
2-2 Heating capacity(Y-5HP)	390
2-3 Cooling capacity(Y-8·10HP,R2-8·10HP)	391
2-4 Heating capacity(Y-8·10HP,R2-8·10HP)	392
2-5 Cooling capacity(Super Y)	393
2-6 Heating capacity(Super Y)	394
2-7 Cooling capacity(PQRY)	395
2-8 Heating capacity(PQRY)	395
3. Sound Levels	396
3-1 Noise levels	396
3-2 N/C curves	396
4. External Dimensions	397
5. Electrical Wiring Diagrams	399
6. Temperature/Airflow distribution	401
7. Options	402

1. Specifications

			PLFY-P32VKM-A	PLFY-P40VKM-A	PLFY-P50VKM-A	PLFY-P63VKM-A
Power source			~ 220-240V 50Hz / ~ 220V 60Hz			
Cooling capacity	*1	kW	3.6	4.5	5.6	7.1
	*2	kcal/h	3,150	4,000	5,000	6,300
Heating capacity	*1	kW	4.0	5.0	6.3	8.0
Power consumption	Cooling	kW	0.13		0.14	0.15
	Heating	kW	0.13		0.14	0.15
Current	Cooling	A	0.60		0.64	0.68
	Heating	A	0.60		0.64	0.68
External finish(Munsel No.)			Panel : 0.70Y 8.59/0.97			
Dimension *3	Height	mm	298(30)			
	Width	mm	660(760)			
	Depth	mm	660(760)			
Net weight *3		kg	19(3.7)			20(3.7)
Heat exchanger			Cross fin (Aluminum plate fin and copper tube)			
Fan	Type		Turbo fan			
	Airflow rate *3 (Low-Mid2-Mid1-High)	m ³ /min	13-14-14.5-15		13-14-15-16	14-15-16-17
	External static pressure	Pa	0			
Motor	Type		Single phase induction motor			
	Output	kW	0.030			
Air filter			PP Honeycomb			
Refrigerant pipe dimension	Gas (Flare)	mm	ø□12.7		ø□15.88	
	Liquid (Flare)	mm	ø□6.35		ø□9.52	
Drain pipe dimension			VP-25			
Noise level (Lo-Mid2-Mid1-Hi) *3		dB(A)	31-32.5-34-35		32-34-35.5-37	35-36.5-38-39

			PLFY-P80VAM-A	PLFY-P100VAM-A	PLFY-P125VAM-A	
Power source			~ 220-240V 50Hz / ~ 220V 60Hz			
Cooling capacity	*1	kW	9.0	11.2	14.0	
	*2	kcal/h	8,000	10,000	12,500	
Heating capacity	*1	kW	10.0	12.5	16.0	
Power consumption	Cooling	kW	0.18	0.30	0.34	
	Heating	kW	0.18	0.30	0.34	
Current	Cooling	A	0.86	1.43	1.64	
	Heating	A	0.86	1.43	1.64	
External finish(Munsel No.)			Panel : 0.70Y 8.59/0.97			
Dimension *3	Height	mm	258(30)	298(30)		
	Width	mm	840(950)			
	Depth	mm	840(950)			
Net weight *3		kg	24(5)	30(5)	30(5)	
Heat exchanger			Cross fin (Aluminum plate fin and copper tube)			
Fan	Type		Turbo fan			
	Airflow rate *3 (Low-Mid2-Mid1-High)	m ³ /min	16-18-20-22	20-23-26-28	22-25-28-30	
	External static pressure	Pa	0			
Motor	Type		Single phase induction motor			
	Output	kW	0.070	0.120		
Air filter			PP Honeycomb			
Refrigerant pipe dimension	Gas (Flare)	mm	ø□15.88		ø□19.05	
	Liquid (Flare)	mm	ø□9.52			
Drain pipe dimension			VP-25			
Noise level (Lo-Mid2-Mid1-Hi) *3		dB(A)	30-32-35-37	33-36-39-41	35-38-41-43	

Note: *1 Cooling/Heating capacity indicates the maximum value at operation under the following condition.

Cooling : Indoor 27°CDB/19°CWB, Outdoor 35°CDB

Heating : Indoor 20°CDB, Outdoor 7°CDB/6°CWB

*2 Cooling capacity indicates the maximum value at operation under the following condition.

Cooling : Indoor 27°CDB/19.5°CWB, Outdoor 35°CDB (WR2: water 30°C)

*3 External dimension/ net weight are shown in (unit/panel) , and airflow rate/noise level are in (low-middle2-middle1-high).

2. Capacity tables

2-1.Cooling Capacity (In combination with PUMY-125YM(A))

PLFY-P-VKM-AVAM-A

CA:Capacity(kW)

SHC:Sensible heat Capacity(kW)

Unit size	Outdoor air temp.	Indoor air temp.							
		23°CDB 16°CWB		25°CDB 18°CWB		28°CDB 20°CWB		30°CDB 22°CWB	
		°CDB	CA	SHC	CA	SHC	CA	SHC	CA
32 (3.6)	20.0	3.6	2.7	3.7	2.8	4.0	2.8	4.2	2.9
	22.5	3.5	2.7	3.7	2.8	4.0	2.8	4.2	2.9
	25.0	3.5	2.7	3.7	2.8	3.9	2.8	4.1	2.8
	27.5	3.4	2.6	3.6	2.8	3.9	2.7	4.1	2.8
	30.0	3.4	2.6	3.6	2.7	3.8	2.7	4.1	2.8
	32.5	3.3	2.6	3.6	2.7	3.8	2.7	4.0	2.8
	35.0	3.3	2.6	3.5	2.7	3.7	2.7	4.0	2.8
	37.5	3.2	2.5	3.5	2.7	3.7	2.6	3.9	2.7
	40.0	3.2	2.5	3.4	2.7	3.6	2.6	3.9	2.7
46.0	3.1	2.5	3.3	2.6	3.5	2.6	3.7	2.7	
40 (4.5)	20.0	4.5	3.4	4.7	3.5	5.0	3.5	5.3	3.6
	22.5	4.4	3.4	4.6	3.5	5.0	3.5	5.2	3.6
	25.0	4.3	3.3	4.6	3.5	4.9	3.5	5.2	3.6
	27.5	4.3	3.3	4.6	3.5	4.9	3.5	5.1	3.6
	30.0	4.2	3.3	4.5	3.5	4.8	3.4	5.1	3.5
	32.5	4.2	3.3	4.4	3.4	4.7	3.4	5.0	3.5
	35.0	4.1	3.2	4.4	3.4	4.7	3.4	5.0	3.5
	37.5	4.1	3.2	4.3	3.4	4.6	3.3	4.9	3.5
	40.0	4.0	3.2	4.3	3.4	4.5	3.3	4.8	3.4
46.0	3.8	3.1	4.1	3.3	4.3	3.2	4.6	3.4	
50 (5.6)	20.0	5.5	4.0	5.8	4.2	6.2	4.1	6.6	4.3
	22.5	5.5	4.0	5.8	4.1	6.2	4.1	6.5	4.2
	25.0	5.4	3.9	5.7	4.1	6.1	4.1	6.4	4.2
	27.5	5.3	3.9	5.7	4.1	6.0	4.1	6.4	4.2
	30.0	5.3	3.9	5.6	4.1	5.9	4.0	6.3	4.1
	32.5	5.2	3.8	5.5	4.0	5.9	4.0	6.2	4.1
	35.0	5.1	3.8	5.5	4.0	5.8	3.9	6.2	4.1
	37.5	5.0	3.7	5.4	3.9	5.7	3.9	6.1	4.0
	40.0	5.0	3.7	5.3	3.9	5.6	3.9	6.0	4.0
46.0	4.8	3.6	5.1	3.8	5.4	3.8	5.8	3.9	
63 (7.1)	20.0	7.0	4.9	7.4	5.1	7.9	5.1	8.3	5.2
	22.5	6.9	4.9	7.3	5.1	7.8	5.1	8.2	5.2
	25.0	6.9	4.8	7.3	5.1	7.7	5.0	8.2	5.2
	27.5	6.8	4.8	7.2	5.0	7.7	5.0	8.1	5.1
	30.0	6.7	4.7	7.1	5.0	7.5	4.9	8.0	5.1
	32.5	6.6	4.7	7.0	4.9	7.5	4.9	7.9	5.0
	35.0	6.5	4.6	6.9	4.9	7.3	4.8	7.8	5.0
	37.5	6.4	4.6	6.8	4.8	7.2	4.8	7.7	5.0
	40.0	6.3	4.6	6.7	4.8	7.2	4.7	7.6	4.9
46.0	6.1	4.4	6.5	4.7	6.9	4.6	7.3	4.8	
80 (9.0)	20.0	8.9	6.4	9.4	6.7	10.0	6.7	10.6	6.9
	22.5	8.8	6.4	9.3	6.7	9.9	6.6	10.4	6.8
	25.0	8.7	6.3	9.2	6.6	9.8	6.6	10.4	6.8
	27.5	8.6	6.3	9.1	6.6	9.7	6.5	10.3	6.7
	30.0	8.5	6.2	9.0	6.5	9.5	6.5	10.2	6.7
	32.5	8.3	6.1	8.9	6.5	9.5	6.4	10.0	6.6
	35.0	8.2	6.1	8.8	6.4	9.3	6.4	9.9	6.6
	37.5	8.1	6.0	8.6	6.4	9.2	6.3	9.8	6.5
	40.0	8.0	6.0	8.6	6.3	9.1	6.2	9.6	6.5
46.0	7.7	5.8	8.2	6.2	8.7	6.1	9.3	6.3	
100 (11.2)	20.0	11.1	8.1	11.6	8.4	12.5	8.4	13.1	8.6
	22.5	10.9	8.0	11.5	8.4	12.3	8.3	13.0	8.6
	25.0	10.8	8.0	11.5	8.3	12.2	8.3	12.9	8.5
	27.5	10.7	7.9	11.3	8.3	12.1	8.2	12.8	8.5
	30.0	10.5	7.8	11.2	8.2	11.9	8.1	12.6	8.4
	32.5	10.4	7.7	11.1	8.2	11.8	8.1	12.5	8.4
	35.0	10.2	7.7	10.9	8.1	11.6	8.0	12.3	8.3
	37.5	10.1	7.6	10.8	8.0	11.4	7.9	12.2	8.2
	40.0	10.0	7.5	10.6	7.9	11.3	7.9	12.0	8.1
46.0	9.6	7.4	10.2	7.8	10.8	7.7	11.5	7.9	
125 (14.0)	20.0	13.9	9.7	14.6	10.1	15.6	10.1	16.4	10.3
	22.5	13.7	9.6	14.4	10.0	15.4	10.0	16.2	10.2
	25.0	13.5	9.5	14.3	10.0	15.3	9.9	16.1	10.2
	27.5	13.4	9.4	14.2	9.9	15.1	9.8	16.0	10.1
	30.0	13.2	9.3	14.0	9.8	14.9	9.7	15.8	10.0
	32.5	13.0	9.2	13.8	9.7	14.7	9.6	15.6	9.9
	35.0	12.8	9.1	13.7	9.6	14.5	9.5	15.4	9.8
	37.5	12.6	9.0	13.4	9.5	14.3	9.4	15.2	9.8
	40.0	12.5	9.0	13.3	9.4	14.1	9.4	15.0	9.7
46.0	12.0	8.7	12.8	9.2	13.5	9.1	14.4	9.4	

PLFY-P-VKM-AVAM-A

2-2.Heating Capacity (In combination with PUMY-125YM(A))

PLFY-P-VKM-A,VAM-A

Unit size	Outdoor air temp. °CWB	Indoor air temp.:°CDB		
		15.0	20.0	25.0
		SHC	SHC	SHC
32	-12.0	2.5	2.5	2.5
	-10.0	2.7	2.6	2.6
	-5.0	3.1	3.0	3.0
	0.0	3.5	3.4	3.4
	2.5	3.7	3.7	3.6
	6.0	4.0	4.0	3.9
	7.5	4.2	4.1	4.0
	10.0	4.4	4.4	4.0
	12.5	4.7	4.4	4.0
	15.5	4.9	4.4	4.0
40	-12.0	3.2	3.1	3.1
	-10.0	3.4	3.3	3.2
	-5.0	3.8	3.8	3.7
	0.0	4.3	4.3	4.2
	2.5	4.6	4.6	4.5
	6.0	5.0	5.0	4.9
	7.5	5.2	5.2	5.0
	10.0	5.5	5.5	5.0
	12.5	5.9	5.5	5.0
	15.5	6.2	5.5	5.0
50	-12.0	4.0	3.9	3.9
	-10.0	4.2	4.2	4.1
	-5.0	4.8	4.8	4.7
	0.0	5.5	5.4	5.3
	2.5	5.8	5.8	5.7
	6.0	6.3	6.3	6.2
	7.5	6.6	6.5	6.2
	10.0	7.0	6.9	6.2
	12.5	7.4	7.0	6.2
	15.5	7.7	7.0	6.2
63	-12.0	5.1	5.0	4.9
	-10.0	5.4	5.3	5.2
	-5.0	6.1	6.0	5.9
	0.0	6.9	6.9	6.8
	2.5	7.4	7.3	7.2
	6.0	8.0	8.0	7.9
	7.5	8.3	8.3	7.9
	10.0	8.8	8.8	7.9
	12.5	9.4	8.8	7.9
	15.5	9.8	8.8	7.9

SHC:Sensible heat Capacity(kW)

Unit size	Outdoor air temp. °CWB	Indoor air temp.:°CDB		
		15.0	20.0	25.0
		SHC	SHC	SHC
80	-12.0	6.4	6.2	6.1
	-10.0	6.7	6.6	6.5
	-5.0	7.6	7.5	7.4
	0.0	8.7	8.6	8.5
	2.5	9.2	9.2	9.0
	6.0	10.1	10.0	9.9
	7.5	10.4	10.4	9.9
	10.0	11.1	11.0	9.9
	12.5	11.7	11.0	9.9
	15.5	12.3	11.0	9.9
100	-12.0	8.0	7.8	7.7
	-10.0	8.4	8.2	8.1
	-5.0	9.6	9.4	9.3
	0.0	10.9	10.7	10.6
	2.5	11.5	11.4	11.3
	6.0	12.6	12.5	12.3
	7.5	13.0	12.9	12.4
	10.0	13.8	13.7	12.4
	12.5	14.6	13.8	12.4
	15.5	15.4	13.8	12.4
125	-12.0	10.2	10.0	9.8
	-10.0	10.7	10.6	10.4
	-5.0	12.2	12.1	11.9
	0.0	13.9	13.8	13.6
	2.5	14.8	14.7	14.5
	6.0	16.1	16.0	15.8
	7.5	16.7	16.6	15.8
	10.0	17.7	17.6	15.8
	12.5	18.7	17.7	15.8
	15.5	19.7	17.7	15.8

PLFY-P-
VKM-A/VAM-A

2-3.Cooling Capacity (In combination with PU(H)Y,PURY-(P)200-250YMF-C)

PLFY-P-VKM-A,VAM-A

CA:Capacity(kW)

SHC:Sensible heat Capacity(kW)

Unit size	Outdoor air temp.	Indoor air temp.													
		21.5°CDB 15°CWB		23°CDB 16°CWB		25°CDB 18°CWB		27°CDB 19°CWB		28°CDB 20°CWB		30°CDB 22°CWB		32°CDB 24°CWB	
		CDB	CA	SHC	CA	SHC	CA	SHC	CA	SHC	CA	SHC	CA	SHC	CA
32 (3.6)	20.0	3.5	2.7	3.6	2.7	3.7	2.7	3.8	2.7	3.9	2.8	4.0	2.7	4.2	2.6
	22.5	3.5	2.7	3.6	2.7	3.7	2.7	3.8	2.7	3.9	2.8	4.0	2.7	4.1	2.6
	25.0	3.5	2.6	3.5	2.7	3.7	2.6	3.7	2.7	3.8	2.8	4.0	2.7	4.1	2.6
	27.5	3.4	2.6	3.5	2.7	3.6	2.6	3.7	2.7	3.8	2.7	3.9	2.7	4.1	2.6
	30.0	3.4	2.6	3.5	2.7	3.6	2.6	3.7	2.6	3.7	2.7	3.9	2.7	4.0	2.6
	32.5	3.3	2.6	3.4	2.7	3.6	2.6	3.6	2.6	3.7	2.7	3.9	2.7	4.0	2.6
	35.0	3.3	2.6	3.4	2.6	3.5	2.6	3.6	2.6	3.7	2.7	3.8	2.6	4.0	2.6
	37.5	3.3	2.6	3.3	2.6	3.5	2.6	3.6	2.6	3.6	2.7	3.8	2.6	3.9	2.6
	40.0	3.2	2.5	3.3	2.6	3.5	2.6	3.5	2.6	3.6	2.7	3.7	2.6	3.9	2.5
43.0	3.2	2.5	3.3	2.6	3.4	2.5	3.5	2.6	3.6	2.7	3.7	2.6	3.8	2.5	
40 (4.5)	20.0	4.4	3.4	4.5	3.5	4.7	3.4	4.8	3.4	4.9	3.5	5.0	3.4	5.2	3.3
	22.5	4.4	3.4	4.5	3.4	4.6	3.4	4.7	3.4	4.8	3.5	5.0	3.4	5.2	3.3
	25.0	4.3	3.3	4.4	3.4	4.6	3.3	4.7	3.4	4.8	3.5	5.0	3.4	5.1	3.3
	27.5	4.3	3.3	4.4	3.4	4.5	3.3	4.6	3.4	4.7	3.5	4.9	3.4	5.1	3.3
	30.0	4.2	3.3	4.3	3.4	4.5	3.3	4.6	3.3	4.7	3.5	4.9	3.4	5.0	3.3
	32.5	4.2	3.3	4.3	3.4	4.5	3.3	4.5	3.3	4.6	3.4	4.8	3.4	5.0	3.3
	35.0	4.1	3.2	4.2	3.3	4.4	3.3	4.5	3.3	4.6	3.4	4.8	3.3	5.0	3.3
	37.5	4.1	3.2	4.2	3.3	4.4	3.2	4.5	3.3	4.5	3.4	4.7	3.3	4.9	3.2
	40.0	4.1	3.2	4.1	3.3	4.3	3.2	4.4	3.3	4.5	3.4	4.7	3.3	4.9	3.2
43.0	4.0	3.2	4.1	3.3	4.3	3.2	4.4	3.2	4.4	3.4	4.6	3.3	4.8	3.2	
50 (5.6)	20.0	5.5	4.0	5.6	4.1	5.8	4.0	5.9	4.0	6.0	4.1	6.3	4.0	6.5	3.9
	22.5	5.4	3.9	5.5	4.0	5.8	3.9	5.9	4.0	6.0	4.1	6.2	4.0	6.4	3.9
	25.0	5.4	3.9	5.5	4.0	5.7	3.9	5.8	3.9	5.9	4.1	6.2	3.9	6.4	3.8
	27.5	5.3	3.9	5.4	4.0	5.7	3.9	5.8	3.9	5.9	4.0	6.1	3.9	6.3	3.8
	30.0	5.3	3.9	5.4	3.9	5.6	3.9	5.7	3.9	5.8	4.0	6.0	3.9	6.3	3.8
	32.5	5.2	3.8	5.3	3.9	5.5	3.8	5.7	3.9	5.8	4.0	6.0	3.9	6.2	3.8
	35.0	5.2	3.8	5.3	3.9	5.5	3.8	5.6	3.8	5.7	4.0	5.9	3.9	6.2	3.8
	37.5	5.1	3.8	5.2	3.9	5.4	3.8	5.5	3.8	5.7	3.9	5.9	3.8	6.1	3.7
	40.0	5.0	3.7	5.2	3.8	5.4	3.8	5.5	3.8	5.6	3.9	5.8	3.8	6.0	3.7
43.0	5.0	3.7	5.1	3.8	5.3	3.7	5.4	3.8	5.5	3.9	5.8	3.8	6.0	3.7	
63 (7.1)	20.0	7.0	4.9	7.1	5.0	7.4	4.9	7.5	4.9	7.7	5.0	8.0	4.9	8.2	4.7
	22.5	6.9	4.9	7.0	4.9	7.3	4.8	7.5	4.8	7.6	5.0	7.9	4.8	8.2	4.7
	25.0	6.8	4.8	7.0	4.9	7.2	4.8	7.4	4.8	7.5	4.9	7.8	4.8	8.1	4.7
	27.5	6.7	4.8	6.9	4.9	7.2	4.8	7.3	4.8	7.5	4.9	7.7	4.8	8.0	4.6
	30.0	6.7	4.7	6.8	4.8	7.1	4.7	7.2	4.7	7.4	4.9	7.7	4.7	8.0	4.6
	32.5	6.6	4.7	6.7	4.8	7.0	4.7	7.2	4.7	7.3	4.8	7.6	4.7	7.9	4.6
	35.0	6.5	4.7	6.7	4.8	7.0	4.7	7.1	4.7	7.2	4.8	7.5	4.7	7.8	4.6
	37.5	6.5	4.6	6.6	4.7	6.9	4.6	7.0	4.6	7.2	4.8	7.5	4.7	7.7	4.5
	40.0	6.4	4.6	6.5	4.7	6.8	4.6	7.0	4.6	7.1	4.8	7.4	4.6	7.7	4.5
43.0	6.3	4.6	6.4	4.6	6.7	4.6	6.9	4.6	7.0	4.7	7.3	4.6	7.6	4.5	
80 (9.0)	20.0	8.8	6.4	9.0	6.5	9.4	6.4	9.5	6.4	9.7	6.6	10.1	6.4	10.4	6.2
	22.5	8.7	6.4	8.9	6.5	9.3	6.3	9.5	6.4	9.6	6.6	10.0	6.4	10.4	6.2
	25.0	8.6	6.3	8.8	6.4	9.2	6.3	9.4	6.3	9.5	6.5	9.9	6.4	10.3	6.2
	27.5	8.6	6.3	8.7	6.4	9.1	6.3	9.3	6.3	9.5	6.5	9.8	6.3	10.2	6.1
	30.0	8.5	6.2	8.6	6.4	9.0	6.2	9.2	6.3	9.4	6.5	9.7	6.3	10.1	6.1
	32.5	8.4	6.2	8.6	6.3	8.9	6.2	9.1	6.2	9.3	6.4	9.6	6.3	10.0	6.1
	35.0	8.3	6.1	8.5	6.3	8.8	6.1	9.0	6.2	9.2	6.4	9.5	6.2	9.9	6.0
	37.5	8.2	6.1	8.4	6.2	8.7	6.1	8.9	6.1	9.1	6.3	9.5	6.2	9.8	6.0
	40.0	8.1	6.0	8.3	6.2	8.6	6.1	8.8	6.1	9.0	6.3	9.4	6.1	9.7	6.0
43.0	8.0	6.0	8.2	6.1	8.5	6.0	8.7	6.1	8.9	6.3	9.3	6.1	9.6	5.9	
100 (11.2)	20.0	11.0	8.0	11.2	8.2	11.6	8.0	11.9	8.1	12.1	8.3	12.5	8.1	13.0	7.9
	22.5	10.9	8.0	11.1	8.2	11.5	8.0	11.8	8.0	12.0	8.3	12.4	8.1	12.9	7.8
	25.0	10.8	7.9	11.0	8.1	11.4	7.9	11.6	8.0	11.9	8.2	12.3	8.0	12.8	7.8
	27.5	10.6	7.9	10.9	8.1	11.3	7.9	11.5	7.9	11.8	8.2	12.2	8.0	12.7	7.8
	30.0	10.5	7.8	10.8	8.0	11.2	7.8	11.4	7.9	11.6	8.1	12.1	7.9	12.5	7.7
	32.5	10.4	7.8	10.6	7.9	11.1	7.8	11.3	7.8	11.5	8.1	12.0	7.9	12.4	7.7
	35.0	10.3	7.7	10.5	7.9	11.0	7.7	11.2	7.8	11.4	8.1	11.9	7.9	12.3	7.6
	37.5	10.2	7.7	10.4	7.8	10.9	7.7	11.1	7.8	11.3	8.0	11.8	7.8	12.2	7.6
	40.0	10.1	7.6	10.3	7.8	10.8	7.6	11.0	7.7	11.2	8.0	11.6	7.8	12.1	7.6
43.0	9.9	7.5	10.2	7.7	10.6	7.6	10.8	7.6	11.1	7.9	11.5	7.7	12.0	7.5	
125 (14.0)	20.0	13.7	9.6	14.0	9.8	14.6	9.6	14.8	9.6	15.1	9.9	15.7	9.6	16.2	9.3
	22.5	13.6	9.6	13.9	9.7	14.4	9.5	14.7	9.5	15.0	9.8	15.5	9.5	16.1	9.2
	25.0	13.4	9.5	13.7	9.7	14.3	9.4	14.6	9.5	14.8	9.7	15.4	9.5	16.0	9.2
	27.5	13.3	9.4	13.6	9.6	14.1	9.4	14.4	9.4	14.7	9.7	15.3	9.4	15.8	9.1
	30.0	13.2	9.3	13.4	9.5	14.0	9.3	14.3	9.3	14.6	9.6	15.1	9.3	15.7	9.1
	32.5	13.0	9.3	13.3	9.4	13.9	9.2	14.1	9.3	14.4	9.5	15.0	9.3	15.5	9.0
	35.0	12.9	9.2	13.2	9.4	13.7	9.2	14.0	9.2	14.3	9.5	14.8	9.2	15.4	9.0
	37.5	12.7	9.1	13.0	9.3	13.6	9.1	13.9	9.1	14.1	9.4	14.7	9.2	15.3	8.9
	40.0	12.6	9.0	12.9	9.2	13.4	9.0	13.7	9.1	14.0	9.4	14.6	9.1	15.1	8.9
43.0	12.4	9.0	12.7	9.1	13.3	9.0	13.6	9.0	13.8	9.3	14.4	9.1	15.0	8.8	

PLFY-P-VKM-A/VAM-A

2-4.Heating Capacity (In combination with PU(H)Y,PURY-(P)200-250YMF-C)

PLFY-P-VKM-A,VAM-A

SHC:Sensible heat Capacity(kW)

Unit size	Outdoor air temp.	Indoor air temp.:°CDB			
		15.0	20.0	25.0	27.0
		°CWB	SHC	SHC	SHC
32	-15.0	2.7	2.6	2.6	2.6
	-10.0	3.1	3.0	3.0	2.8
	-5.0	3.4	3.4	3.1	2.8
	0.0	3.8	3.8	3.1	2.8
	2.5	4.0	4.0	3.1	2.8
	6.0	4.0	4.0	3.1	2.8
	7.5	4.2	4.0	3.1	2.8
	10.0	4.5	4.0	3.1	2.8
	12.5	4.8	4.0	3.1	2.8
	15.5	4.8	4.0	3.1	2.8
40	-15.0	3.3	3.3	3.3	3.3
	-10.0	3.8	3.8	3.7	3.5
	-5.0	4.3	4.2	3.9	3.5
	0.0	4.8	4.7	3.9	3.5
	2.5	5.0	5.0	3.9	3.5
	6.0	5.1	5.0	3.9	3.5
	7.5	5.3	5.0	3.9	3.5
	10.0	5.6	5.0	3.9	3.5
	12.5	6.0	5.0	3.9	3.5
	15.5	6.1	5.0	3.9	3.5
50	-15.0	4.2	4.2	4.1	4.1
	-10.0	4.8	4.8	4.7	4.3
	-5.0	5.4	5.3	4.9	4.3
	0.0	6.0	5.9	4.9	4.3
	2.5	6.3	6.2	4.9	4.3
	6.0	6.4	6.3	4.9	4.3
	7.5	6.6	6.3	4.9	4.3
	10.0	7.1	6.3	4.9	4.3
	12.5	7.5	6.3	4.9	4.3
	15.5	7.6	6.3	4.9	4.3
63	-15.0	5.4	5.3	5.2	5.2
	-10.0	6.1	6.0	6.0	5.5
	-5.0	6.9	6.8	6.2	5.5
	0.0	7.6	7.5	6.2	5.5
	2.5	8.0	7.9	6.2	5.5
	6.0	8.1	8.0	6.2	5.5
	7.5	8.4	8.0	6.2	5.5
	10.0	9.0	8.0	6.2	5.5
	12.5	9.6	8.0	6.2	5.5
	15.5	9.7	8.0	6.2	5.5

Unit size	Outdoor air temp.	Indoor air temp.:°CDB			
		15.0	20.0	25.0	27.0
		°CWB	SHC	SHC	SHC
80	-15.0	6.7	6.6	6.5	6.5
	-10.0	7.6	7.5	7.4	6.9
	-5.0	8.6	8.5	7.8	6.9
	0.0	9.5	9.4	7.8	6.9
	2.5	10.0	9.9	7.8	6.9
	6.0	10.1	10.0	7.8	6.9
	7.5	10.5	10.0	7.8	6.9
	10.0	11.2	10.0	7.8	6.9
	12.5	12.0	10.0	7.8	6.9
	15.5	12.1	10.0	7.8	6.9
100	-15.0	8.4	8.2	8.2	8.1
	-10.0	9.6	9.4	9.3	8.6
	-5.0	10.7	10.6	9.8	8.6
	0.0	11.9	11.8	9.8	8.6
	2.5	12.5	12.4	9.8	8.6
	6.0	12.6	12.5	9.8	8.6
	7.5	13.2	12.5	9.8	8.6
	10.0	14.1	12.5	9.8	8.6
	12.5	15.0	12.5	9.8	8.6
	15.5	15.1	12.5	9.8	8.6
125	-15.0	10.7	10.6	10.5	10.4
	-10.0	12.2	12.1	11.9	11.0
	-5.0	13.7	13.6	12.5	11.0
	0.0	15.3	15.1	12.5	11.0
	2.5	16.0	15.8	12.5	11.0
	6.0	16.2	16.0	12.5	11.0
	7.5	16.8	16.0	12.5	11.0
	10.0	18.0	16.0	12.5	11.0
	12.5	19.1	16.0	12.5	11.0
	15.5	19.4	16.0	12.5	11.0

PLFY-P-VKM-A/VAM-A

**2-5.Cooling capacity
(In combination with PUHY-(P)315-400-500-600-650-700-750Y(S)MF-B,Y(S)MC)**

PLFY-P-VKM-A,VAM-A

CA:Capacity(kcal/h)

SHC:Sensible heat Capacity(kcal/h)

Unit size	Outdoor air temp. °CDB	Indoor air temp.													
		21.5°CDB 15°CWB		23°CDB 16°CWB		25°CDB 18°CWB		27°CDB 19.5°CWB		28°CDB 20°CWB		30°CDB 22°CWB		32°CDB 24°CWB	
		CA	SHC	CA	SHC	CA	SHC	CA	SHC	CA	SHC	CA	SHC	CA	SHC
32	20.0	2855	2215	2995	2308	3227	2307	3398	2374	3452	2445	3654	2411	3872	2374
	22.5	2855	2215	2983	2302	3199	2295	3357	2357	3409	2427	3606	2393	3817	2355
	25.0	2833	2204	2954	2289	3163	2279	3315	2340	3366	2410	3558	2374	3763	2336
	27.5	2810	2193	2925	2275	3127	2263	3274	2323	3323	2392	3510	2356	3708	2317
	30.0	2787	2182	2896	2262	3091	2247	3233	2306	3280	2375	3462	2338	3653	2298
	32.5	2765	2172	2868	2249	3055	2232	3191	2289	3237	2358	3414	2320	3598	2279
	35.0	2742	2161	2839	2235	3018	2216	3150	2272	3194	2340	3366	2302	3544	2260
	37.5	2719	2150	2810	2222	2982	2201	3109	2255	3151	2323	3318	2285	3489	2242
	40.0	2696	2139	2781	2209	2946	2185	3067	2238	3109	2306	3270	2267	3434	2223
43.0	2669	2126	2746	2193	2902	2166	3018	2218	3057	2285	3212	2246	3368	2201	
40	20.0	3625	2821	3803	2940	4098	2939	4315	3025	4383	3116	4640	3072	4917	3026
	22.5	3625	2821	3788	2933	4063	2923	4262	3003	4329	3094	4579	3049	4848	3001
	25.0	3597	2808	3751	2916	4017	2903	4210	2981	4274	3071	4518	3026	4778	2977
	27.5	3568	2794	3715	2899	3971	2883	4157	2960	4220	3049	4457	3003	4708	2953
	30.0	3539	2780	3678	2882	3925	2863	4105	2938	4165	3027	4396	2980	4639	2929
	32.5	3511	2766	3641	2865	3879	2843	4052	2917	4111	3005	4335	2957	4569	2905
	35.0	3482	2753	3605	2848	3833	2823	4000	2895	4056	2983	4274	2935	4500	2881
	37.5	3453	2739	3568	2831	3787	2804	3948	2874	4002	2961	4213	2912	4430	2857
	40.0	3424	2725	3531	2815	3741	2784	3895	2852	3947	2940	4152	2889	4361	2834
43.0	3389	2709	3487	2794	3686	2760	3832	2827	3882	2914	4078	2863	4277	2806	
50	20.0	4532	3322	4753	3454	5123	3457	5393	3548	5479	3644	5800	3591	6146	3535
	22.5	4532	3322	4735	3445	5078	3436	5328	3520	5411	3614	5724	3561	6059	3503
	25.0	4496	3304	4689	3423	5021	3410	5262	3491	5343	3585	5648	3530	5972	3471
	27.5	4460	3286	4643	3400	4963	3384	5197	3462	5275	3556	5571	3500	5886	3439
	30.0	4424	3268	4597	3378	4906	3357	5131	3434	5207	3527	5495	3470	5799	3407
	32.5	4388	3249	4552	3356	4848	3331	5066	3405	5139	3498	5419	3439	5712	3375
	35.0	4352	3231	4506	3333	4791	3305	5000	3377	5070	3469	5342	3410	5625	3344
	37.5	4316	3214	4460	3311	4734	3279	4934	3349	5002	3440	5266	3380	5538	3313
	40.0	4280	3196	4414	3289	4676	3253	4869	3321	4934	3412	5190	3350	5451	3282
43.0	4237	3174	4359	3263	4607	3222	4790	3288	4852	3377	5098	3315	5347	3244	
63	20.0	5710	4063	5989	4220	6455	4227	6796	4332	6904	4441	7309	4376	7744	4306
	22.5	5710	4063	5966	4209	6399	4200	6713	4295	6818	4402	7212	4336	7635	4264
	25.0	5665	4040	5908	4179	6326	4166	6630	4257	6732	4364	7116	4296	7525	4222
	27.5	5620	4016	5851	4150	6254	4131	6548	4220	6646	4326	7020	4256	7416	4180
	30.0	5574	3992	5793	4121	6181	4097	6465	4182	6560	4288	6924	4217	7306	4138
	32.5	5529	3969	5735	4092	6109	4063	6383	4145	6475	4250	6828	4177	7197	4097
	35.0	5484	3945	5677	4063	6037	4029	6300	4109	6389	4212	6731	4138	7087	4056
	37.5	5438	3922	5620	4034	5964	3995	6217	4072	6303	4175	6635	4099	6978	4015
	40.0	5393	3899	5562	4005	5892	3961	6135	4035	6217	4137	6539	4060	6868	3974
43.0	5338	3871	5493	3971	5805	3921	6036	3992	6114	4093	6424	4014	6737	3926	
80	20.0	7251	5334	7605	5548	8196	5551	8629	5699	8767	5854	9281	5769	9834	5678
	22.5	7251	5334	7576	5533	8125	5518	8525	5653	8658	5807	9159	5720	9695	5627
	25.0	7194	5305	7503	5497	8033	5476	8420	5607	8549	5760	9036	5672	9556	5575
	27.5	7136	5276	7429	5462	7941	5434	8315	5562	8440	5714	8914	5623	9417	5525
	30.0	7079	5247	7356	5426	7849	5392	8210	5516	8331	5667	8792	5575	9278	5474
	32.5	7021	5219	7283	5391	7758	5350	8105	5471	8222	5621	8670	5527	9139	5424
	35.0	6963	5190	7209	5355	7666	5309	8000	5426	8113	5575	8548	5479	9000	5374
	37.5	6906	5161	7136	5320	7574	5268	7895	5381	8004	5529	8426	5432	8861	5324
	40.0	6848	5133	7063	5285	7482	5226	7790	5337	7895	5484	8304	5385	8722	5274
43.0	6779	5098	6975	5243	7371	5177	7664	5283	7764	5429	8157	5328	8555	5215	
100	20.0	9063	6734	9507	7007	10245	7009	10787	7200	10958	7400	11601	7293	12293	7179
	22.5	9063	6734	9470	6989	10157	6969	10656	7143	10822	7342	11448	7233	12119	7115
	25.0	8993	6699	9378	6945	10042	6917	10525	7087	10686	7284	11296	7173	11945	7052
	27.5	8920	6663	9287	6901	9927	6865	10393	7030	10550	7227	11143	7113	11771	6989
	30.0	8848	6627	9195	6857	9812	6813	10262	6974	10413	7169	10990	7053	11597	6926
	32.5	8776	6592	9103	6813	9697	6761	10131	6918	10277	7112	10837	6994	11423	6864
	35.0	8704	6556	9012	6769	9582	6710	10000	6863	10141	7055	10685	6935	11250	6802
	37.5	8632	6521	8920	6725	9467	6659	9869	6807	10005	6999	10532	6876	11076	6741
	40.0	8560	6485	8828	6681	9352	6608	9738	6752	9868	6942	10379	6818	10902	6679
43.0	8474	6443	8718	6629	9214	6547	9580	6686	9705	6875	10196	6748	10693	6606	
125	20.0	11329	8037	11883	8348	12807	8362	13484	8569	13698	8782	14501	8653	15366	8513
	22.5	11329	8037	11837	8325	12696	8309	13320	8494	13527	8705	14310	8573	15149	8429
	25.0	11241	7991	11723	8267	12552	8240	13156	8419	13357	8629	14119	8493	14931	8345
	27.5	11151	7944	11608	8208	12408	8171	12992	8344	13187	8553	13929	8414	14714	8262
	30.0	11060	7897	11494	8150	12265	8103	12828	8270	13017	8477	13738	8335	14497	8179
	32.5	10970	7850	11379	8092	12121	8035	12664	8197	12846	8402	13547	8257	14279	8097
	35.0	10880	7804	11265	8035	11977	7967	12500	8123	12676	8327	13356	8179	14062	8015
	37.5	10790	7757	11150	7977	11834	7900	12336	8050	12506	8252	13165	8102	13845	7934
	40.0	10700	7711	11035	7920	11690	7833	12172	7978	12335	8178	12974	8025	13627	7853
43.0	10592	7655	10898	7852	11518	7753	11975	7891	12131	8089	12745	7933	13367	7757	

**PLFY-P-
VKM-A/VAM-A**

**2-6.Heating capacity
(In combination with PUHY-(P)315-400-500-600-650-700-750Y(S)MF-B,Y(S)MC)**

PLFY-P-VKM-A,VAM-A

SHC:Sensible heat Capacity(kcal/h)

Unit size	Outdoor air temp.	Indoor air temp.:°CDB			
		15	21	25	27
	°CWB	SHC	SHC	SHC	SHC
32	-15.0	2454	2417	2381	2366
	-10.0	2800	2763	2727	2525
	-5.0	3146	3109	2855	2525
	0.0	3491	3455	2855	2525
	2.5	3664	3550	2855	2525
	6.0	3696	3550	2855	2525
	7.5	3852	3550	2855	2525
	10.0	4111	3550	2855	2525
	12.5	4370	3550	2855	2525
	15.5	4428	3550	2855	2525
40	-15.0	3111	3064	3018	2999
	-10.0	3549	3503	3456	3201
	-5.0	3987	3941	3619	3201
	0.0	4426	4379	3619	3201
	2.5	4645	4500	3619	3201
	6.0	4686	4500	3619	3201
	7.5	4883	4500	3619	3201
	10.0	5211	4500	3619	3201
	12.5	5539	4500	3619	3201
	15.5	5613	4500	3619	3201
50	-15.0	3871	3813	3755	3732
	-10.0	4416	4359	4301	3984
	-5.0	4962	4904	4503	3984
	0.0	5508	5450	4503	3984
	2.5	5780	5600	4503	3984
	6.0	5831	5600	4503	3984
	7.5	6076	5600	4503	3984
	10.0	6484	5600	4503	3984
	12.5	6893	5600	4503	3984
	15.5	6986	5600	4503	3984
63	-15.0	4908	4835	4761	4732
	-10.0	5599	5526	5453	5051
	-5.0	6291	6218	5709	5051
	0.0	6983	6910	5709	5051
	2.5	7329	7100	5709	5051
	6.0	7393	7100	5709	5051
	7.5	7704	7100	5709	5051
	10.0	8221	7100	5709	5051
	12.5	8739	7100	5709	5051
	15.5	8857	7100	5709	5051

Unit size	Outdoor air temp.	Indoor air temp.:°CDB			
		15	21	25	27
	°CWB	SHC	SHC	SHC	SHC
80	-15.0	6221	6128	6036	5998
	-10.0	7098	7005	6912	6402
	-5.0	7975	7882	7237	6402
	0.0	8852	8759	7237	6402
	2.5	9290	9000	7237	6402
	6.0	9371	9000	7237	6402
	7.5	9765	9000	7237	6402
	10.0	10421	9000	7237	6402
	12.5	11078	9000	7237	6402
	15.5	11227	9000	7237	6402
100	-15.0	7742	7626	7511	7465
	-10.0	8833	8718	8602	7967
	-5.0	9924	9809	9006	7967
	0.0	11015	10900	9006	7967
	2.5	11561	11200	9006	7967
	6.0	11662	11200	9006	7967
	7.5	12152	11200	9006	7967
	10.0	12969	11200	9006	7967
	12.5	13786	11200	9006	7967
	15.5	13971	11200	9006	7967
125	-15.0	9677	9533	9389	9331
	-10.0	11041	10897	10753	9959
	-5.0	12405	12261	11258	9959
	0.0	13769	13625	11258	9959
	2.5	14451	14000	11258	9959
	6.0	14577	14000	11258	9959
	7.5	15190	14000	11258	9959
	10.0	16211	14000	11258	9959
	12.5	17232	14000	11258	9959
	15.5	17464	14000	11258	9959

PLFY-P-VKM-A/VAM-A

2-7.Cooling Capacity (In combination with PQRV-P200-250YMF-B)

PLFY-P-VKM-A,VAM-A

CA:Capacity(kcal/h)
SHC:Sensible heat Capacity(kcal/h)

Unit size	Water temp.	Indoor air temp.													
		21.5°CDB 15°CWB		23°CDB 16°CWB		25°CDB 18°CWB		27°CDB 19.5°CWB		28°CDB 20°CWB		30°CDB 22°CWB		32°CDB 24°CWB	
		CA	SHC	CA	SHC	CA	SHC	CA	SHC	CA	SHC	CA	SHC	CA	SHC
32	10	3015	2292	3119	2366	3316	2346	3465	2402	3510	2469	3708	2431	3915	2390
	20	2905	2239	3005	2313	3195	2293	3339	2350	3382	2416	3573	2380	3773	2340
	30	2741	2160	2835	2234	3015	2214	3150	2272	3191	2339	3371	2304	3560	2266
	40	2384	1993	2466	2066	2623	2049	2741	2107	2776	2175	2932	2144	3097	2110
	45	2247	1931	2325	2004	2472	1986	2583	2046	2617	2114	2764	2084	2919	2051
40	10	3828	2919	3960	3014	4211	2988	4400	3061	4457	3146	4708	3098	4972	3045
	20	3689	2852	3816	2946	4058	2921	4240	2994	4295	3080	4537	3033	4791	2982
	30	3480	2752	3600	2846	3828	2821	4000	2895	4052	2982	4280	2937	4520	2888
	40	3028	2540	3132	2634	3330	2611	3480	2687	3525	2774	3724	2734	3932	2690
	45	2854	2461	2952	2554	3139	2532	3280	2608	3323	2696	3510	2658	3706	2616
50	10	4785	3451	4950	3552	5264	3522	5500	3596	5572	3684	5885	3625	6215	3561
	20	4611	3362	4770	3462	5072	3434	5300	3507	5369	3596	5671	3539	5989	3477
	30	4350	3230	4500	3331	4785	3302	5000	3377	5065	3467	5350	3413	5650	3353
	40	3785	2954	3915	3053	4163	3027	4350	3104	4407	3194	4655	3146	4916	3093
	45	3567	2850	3690	2949	3924	2924	4100	3002	4153	3093	4387	3047	4633	2997
63	10	6029	4231	6237	4348	6632	4313	6930	4394	7020	4493	7415	4421	7831	4340
	20	5810	4115	6010	4231	6391	4197	6678	4279	6765	4378	7145	4308	7546	4230
	30	5481	3944	5670	4059	6029	4026	6300	4109	6382	4209	6741	4142	7119	4068
	40	4768	3585	4933	3699	5245	3667	5481	3753	5552	3855	5865	3795	6194	3729
	45	4494	3451	4649	3564	4944	3533	5166	3620	5233	3723	5528	3666	5838	3603
80	10	7656	5539	7920	5703	8422	5655	8800	5774	8914	5918	9416	5823	9944	5719
	20	7378	5398	7632	5561	8115	5514	8480	5634	8590	5778	9074	5686	9582	5585
	30	6960	5188	7200	5351	7656	5305	8000	5426	8104	5572	8560	5484	9040	5388
	40	6055	4747	6264	4908	6661	4865	6960	4990	7050	5138	7447	5060	7865	4974
	45	5707	4582	5904	4742	6278	4700	6560	4827	6645	4975	7019	4901	7413	4820
100	10	9570	6989	9900	7200	10527	7138	11000	7293	11143	7479	11770	7360	12430	7229
	20	9222	6814	9540	7024	10144	6963	10600	7119	10738	7306	11342	7191	11978	7064
	30	8700	6554	9000	6763	9570	6705	10000	6863	10130	7051	10700	6941	11300	6820
	40	7569	6007	7830	6215	8326	6160	8700	6322	8813	6513	9309	6415	9831	6308
	45	7134	5802	7380	6009	7847	5956	8200	6120	8307	6312	8774	6218	9266	6116
125	10	11963	8373	12375	8602	13159	8533	13750	8692	13929	8887	14713	8742	15538	8580
	20	11528	8142	11925	8370	12680	8301	13250	8462	13422	8658	14178	8517	14973	8361
	30	10875	7801	11250	8028	11963	7960	12500	8123	12663	8321	13375	8187	14125	8039
	40	9461	7086	9788	7309	10407	7246	10875	7414	11016	7615	11636	7496	12289	7365
	45	8918	6819	9225	7042	9809	6980	10250	7150	10383	7352	10968	7239	11583	7115

2-8.Heating Capacity (In combination with PQRV-P200-250YMF-B)

PLFY-P-VKM-A,VAM-A

SHC:Sensible heat Capacity(kcal/h)

Unit size	Water temp.	Indoor air temp.:°CDB			
		15	21	25	27
		SHC	SHC	SHC	SHC
32	10	3078	3018	2444	2173
	20	3621	3550	2876	2556
	30	3621	3550	2876	2556
	40	3766	3692	2991	2658
	45	4128	4047	3278	2914
40	10	3902	3825	3098	2754
	20	4590	4500	3645	3240
	30	4590	4500	3645	3240
	40	4774	4680	3791	3370
	45	5233	5130	4155	3694
50	10	4855	4760	3856	3427
	20	5712	5600	4536	4032
	30	5712	5600	4536	4032
	40	5940	5824	4717	4193
	45	6512	6384	5171	4596
63	10	6156	6035	4888	4345
	20	7242	7100	5751	5112
	30	7242	7100	5751	5112
	40	7532	7384	5981	5316
	45	8256	8094	6556	5828

Unit size	Water temp.	Indoor air temp.:°CDB			
		15	21	25	27
		SHC	SHC	SHC	SHC
80	10	7803	7650	6197	5508
	20	9180	9000	7290	6480
	30	9180	9000	7290	6480
	40	9547	9360	7582	6739
	45	10465	10260	8311	7387
100	10	9710	9520	7711	6854
	20	11424	11200	9072	8064
	30	11424	11200	9072	8064
	40	11881	11648	9435	8387
	45	13023	12768	10342	9193
125	10	12138	11900	9639	8568
	20	14280	14000	11340	10080
	30	14280	14000	11340	10080
	40	14851	14560	11794	10483
	45	16279	15960	12928	11491

PLFY-P-VKM-A/VAM-A

3. Sound levels

3-1. Noise level

Cassette ceiling (VKM-A/VAM-A series)

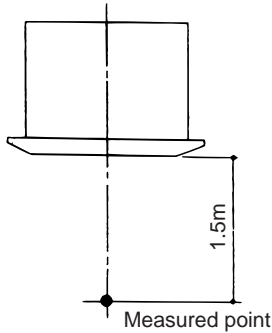

Noise level at anechoic room
(Low-Middle2-Middle1-High)

Unit : dB(A)

Model	Noise level (A weighted)
PLFY-P32VKM-A PLFY-P40VKM-A	31-32.5-34-35
PLFY-P50VKM-A	32-34-35.5-37
PLFY-P63VKM-A	35-36.5-38-39
PLFY-P80VAM-A	30-32-35-37
PLFY-P100VAM-A	33-36-39-41
PLFY-P125VAM-A	35-38-41-43

3-2. NC curves

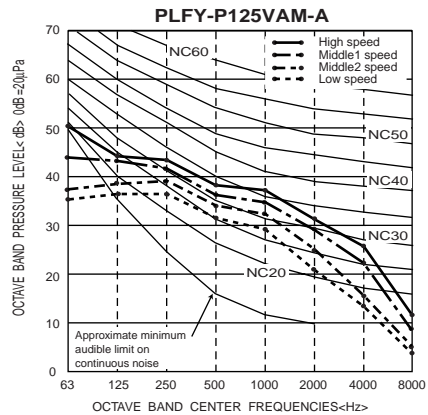
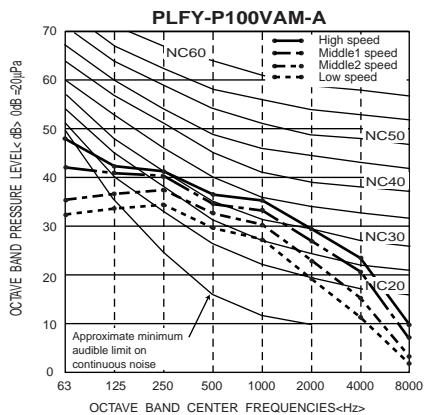
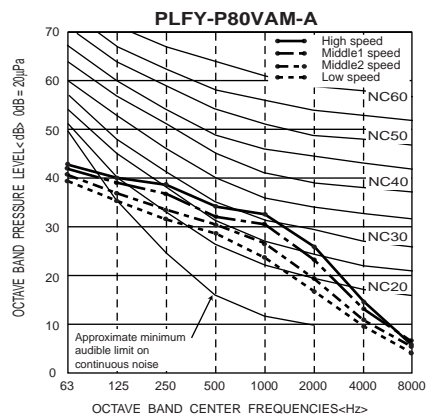
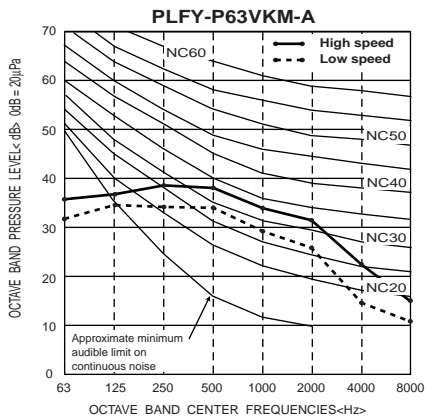
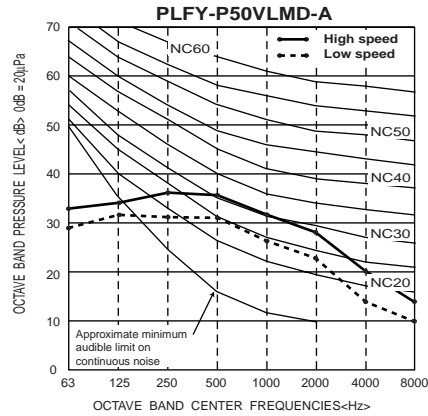
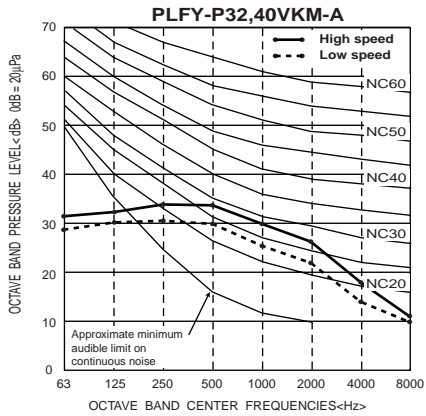

PLFY-P-
VKM-A/VAM-A

4. External Dimensions

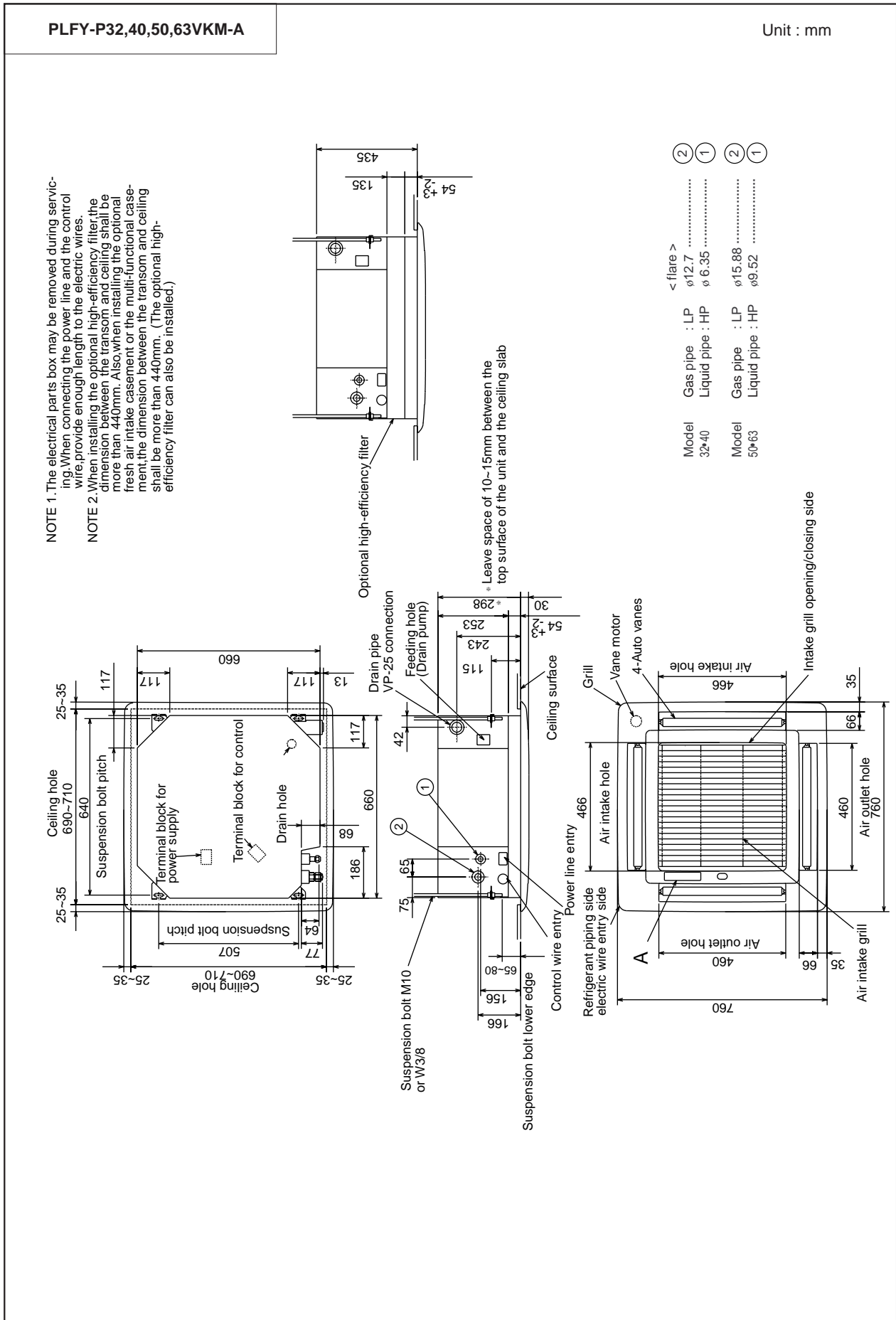

PLFY-P-VKM-A/VAM-A

PLFY-P80,100,125VAM-A

Unit : mm

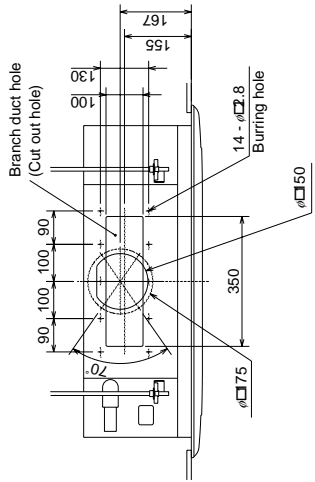
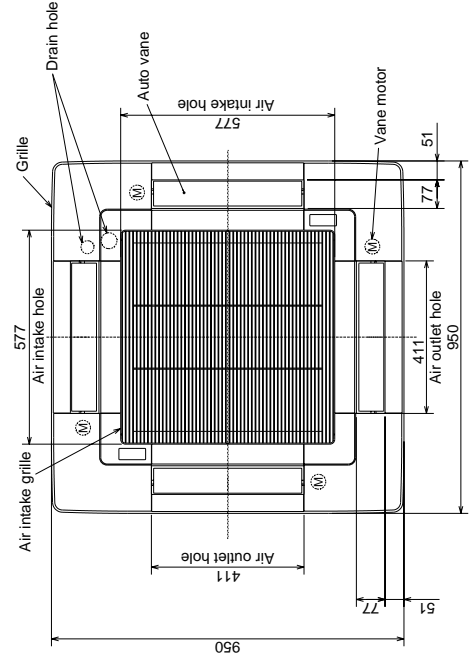
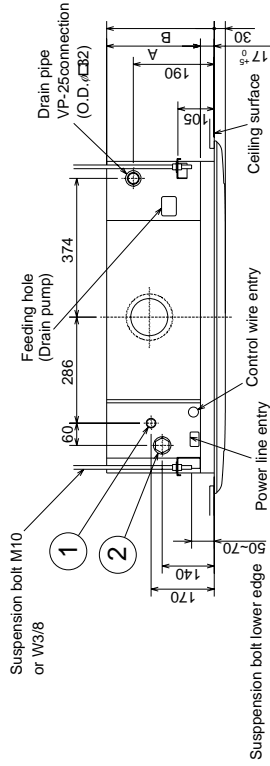
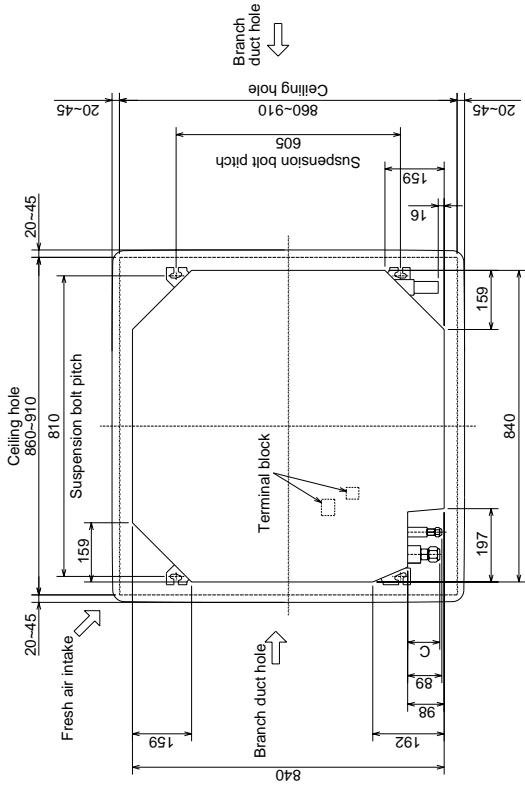

Detail drawing of fresh air intake

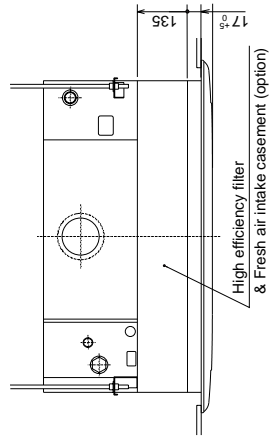
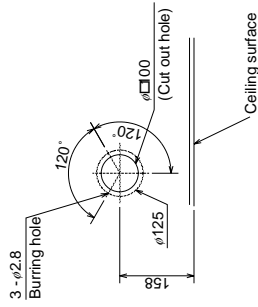

Models	①	②	A	B	C
PLFY-P80VAM-A	Refrigerant pipe (9.52mm dia.) flared connection 3/8F	Refrigerant pipe (15.88mm dia.) flared connection 5/8F	241	258	80
PLFY-P100, 125VAM-A	Refrigerant pipe (9.52mm dia.) flared connection 3/8F	Refrigerant pipe (19.05mm dia.) flared connection 3/4F	281	298	84

5. Electrical Wiring Diagrams

● PLFY-P32 ~ 63VKM-A

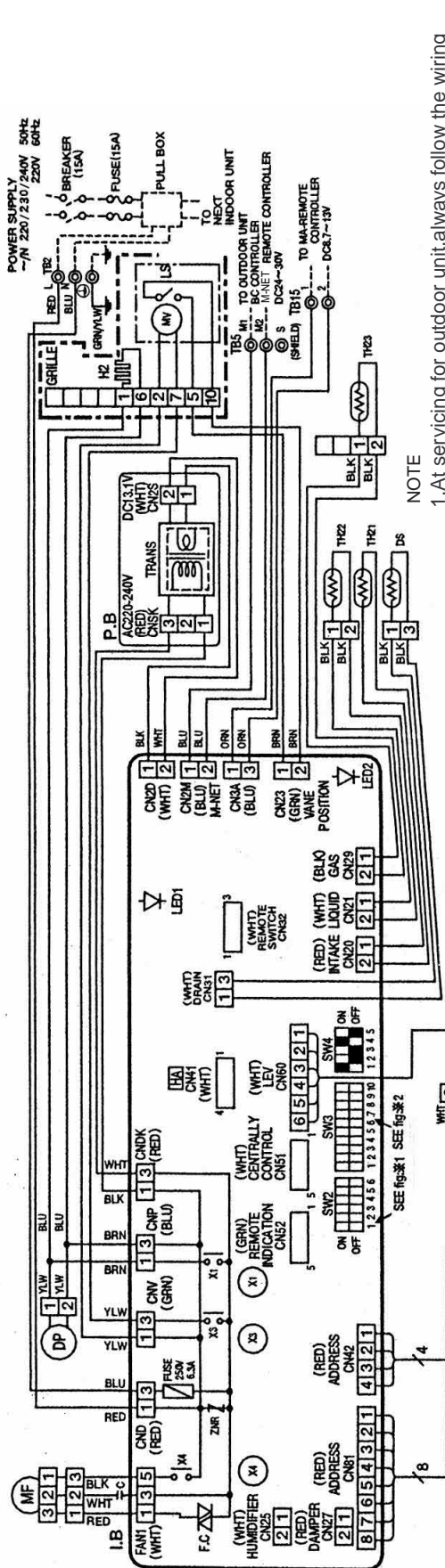

- NOTE**
- At servicing for outdoor unit, always follow the wiring diagram of outdoor unit.
 - In case of using MA-Remote controller, please connect to TB15.
 - In case of using M-NET, please connect to TB5. (Transmission line is non-polar.)
 - Symbol[s] of TB5 is the shield wire connection.
 - Symbol[s] used in wiring diagram above are,
 - Terminal block
 - Connector
 - The setting of the SW2 dip switches differs in the capacity. For the detail, refer to the fig. #1.
 - Please set the switch SW5 according to the power supply voltage.
 - Set SW5 to 240V side when the power supply is 230 and 240 volts.
 - When the power supply is 220 volts, set SW5 to 220V side.

SYMBOL	NAME	SYMBOL	NAME
IB	INDOOR CONTROLLER BOARD	A.B	CIRCUIT BOARD (ADDRESS)
CN25	CONNECTOR/HUMIDIFIER	SW1	MODE SELECTION SWITCH
CN27	DAMPER	SW11	VOLTAGE SELECTION
CN41	REMOTE SWITCH	SW12	ADDRESS SETTING 1ST DIGIT
CN51	HA TERMINAL-A	SW14	ADDRESS SETTING 2ND DIGIT
CN52	CENTRALLY CONTROL	SWA	CONNECTION NO.
SW2	SWITCH	SWB	CEILING HEIGHT SELECTOR
SW3	CAPACITY CODE	SWC	DISCHARGE OUTLET NUMBER SELECTOR
SW4	MODEL SELECTION	SW21	OPTION SELECTOR
ZNR	VARIABLE	TH21	ROOM TEMP DETECTION
FUSE(6.3A)	FUSE	TH22	(0 C/15K ,25 C/5.4K)
FC	FAN PHASE CONTROL	TH23	PIPE TEMP DETECTION/LIQUID
X1	AUX.RELAY	X3	(0 C/15K ,25 C/5.4K)
X4	VANE	X4	PIPE TEMP DETECTION/GAS
FMV	FAN MOTOR	LEV	(0 C/15K ,25 C/5.4K)
LED1	POWER SUPPLY (L)	PB	LINEAR EXPANSION VALVE
LED2	POWER SUPPLY (R)	LS	INDOOR POWER BOARD
MF	FAN MOTOR (WITH INNER THERMO.)	L2	CAPACITOR (FAN MOTOR)
IMV	VANE MOTOR	H2	LEMIT SWITCH
TB2	TERMINAL POWER SUPPLY	DP	DRAIN PREVENTION HEATER
TB5	BLOCK	DS	DRAIN WATER LIFTING-UP MACH.
TB15	MA-REMOTE CONTROLLER	DS	DRAIN SENSOR

Led on indoor board for service

Mark	Meaning	Function
LED1	Main power supply	Main power supply (indoor unit:220-240V) power on → lamp is lit
LED2	Power supply for MA-Remote controller	Power supply for MA-Remote controller on → lamp is lit

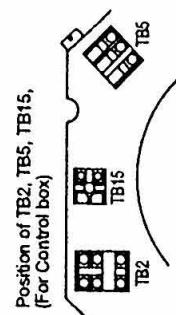

<fig.#1>

MODELS	SW2	MODELS	SW2
P32	ON OFF 1 2 3 4 5 6	P50	ON OFF 1 2 3 4 5 6
P40	ON OFF 1 2 3 4 5 6	P63	ON OFF 1 2 3 4 5 6

<fig.#2>

MODELS	SW3
P32, P40	ON OFF 1 2 3 4 5 6 7 8 9 10
P50, P63	ON OFF 1 2 3 4 5 6 7 8 9 10



● PLFY-P80 ~ 125VAM-A

[LEGEND]

SYMBOL	NAME	SYMBOL	NAME	SYMBOL	NAME
P.B	INDOOR POWER BOARD	C	CAPACITOR(FAN MOTOR)	TH23	THERMISTOR PIPE TEMPERATURE DETECTION / GAS (0°C/15kΩ, 25°C/5.4kΩ)
I.B	INDOOR CONTROLLER BOARD	MF	FAN MOTOR(WITH INNER THERMO)	A.B	CIRCUIT BOARD
CN25	CONNECTOR HUMIDIFIER	MV	VANE MOTOR	SW1	SWITCH MODE SELECTION
CN32	CONNECTOR REMOTE SWITCH	DP	DRAIN WATER LIFTING-UP MACH	SW5	SWITCH VOLTAGE SELECTION
CN41	CONNECTOR HA TERMINAL-A	DS	DRAIN SENSOR	SW11	SWITCH ADDRESS SETTING 1ST DIGIT
CN51	CONNECTOR CENTRALLY CONTROL	H2	DEW PREVENTION HEATER	SW12	SWITCH ADDRESS SETTING 2ND DIGIT
CN52	CONNECTOR REMOTE INDICATION	TB2	TERMINAL BLOCK POWER SUPPLY TRANSMISSION	SW14	SWITCH CONNECTION No.
SW2	SWITCH CAPACITY CODE	TB5	TERMINAL BLOCK LINEAR EXPANSION VALVE	SWA	SWITCH CEILING HEIGHT SELECTOR
SW3	SWITCH MODE SELECTION	TB15	TERMINAL BLOCK ROOM TEMPERATURE DETECTION (0°C/15kΩ, 25°C/5.4kΩ)	SWB	SWITCH DISCHARGE OUTLET NUMBER SELECTOR
SW4	SWITCH MODEL SELECTION	LEV	LINEAR EXPANSION VALVE	SWC	SWITCH OPTION SELECTOR
ZNR	VARIATOR	TH21	THERMISTOR PIPE TEMPERATURE DETECTION / LIQUID (0°C/15kΩ, 25°C/5.4kΩ)		
FUSE	FUSE (6.3A/250V)	TH22	THERMISTOR ROOM TEMPERATURE DETECTION (0°C/15kΩ, 25°C/5.4kΩ)		
F.C	FAN PHASE CONTROL				
X1	AUX.RELAY DRAIN PUMP				
X4	FAN MOTOR				
LED1	POWER SUPPLY(I.B)				
LED2	POWER SUPPLY(I.B)				

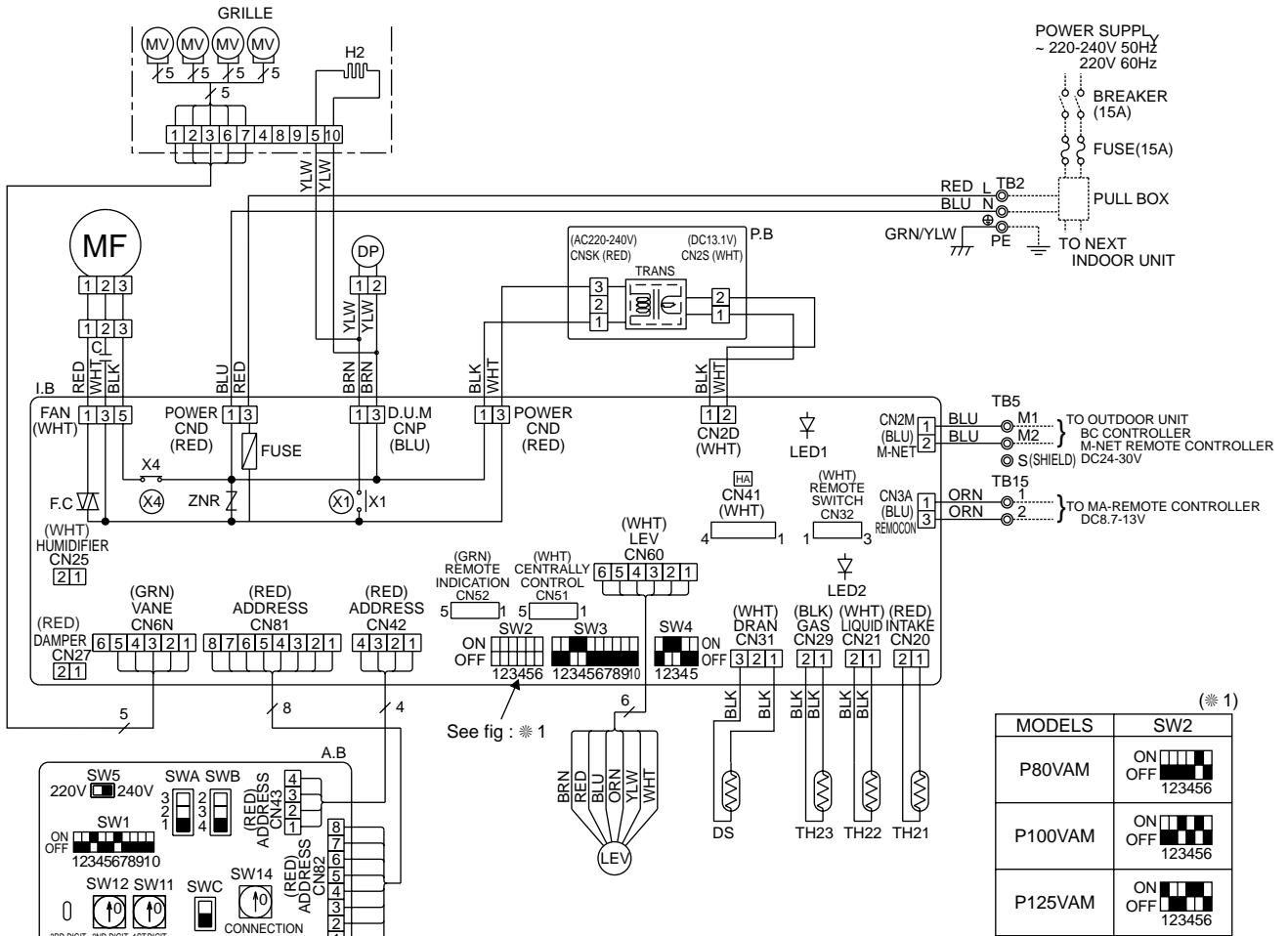

NOTE

1. At servicing for outdoor unit, always follow the wiring diagram of outdoor unit.
2. Symbol(S) of TB5 is the shield wire connection.
3. Symbols used in wiring diagram above are, ⊙: Terminal block, □□□□: Connector.
4. The setting of the SW2 dip switches differs in the capacity for the detail, see the table below.
5. Please set the switch SW5 according to the power supply voltage.
Set SW5 to 240V side when the power supply is 230 and 240 volts.
When the power supply is 220 volts, set SW5 to 220V side.

6. Temperature/Airflow distribution

● Temperature distribution

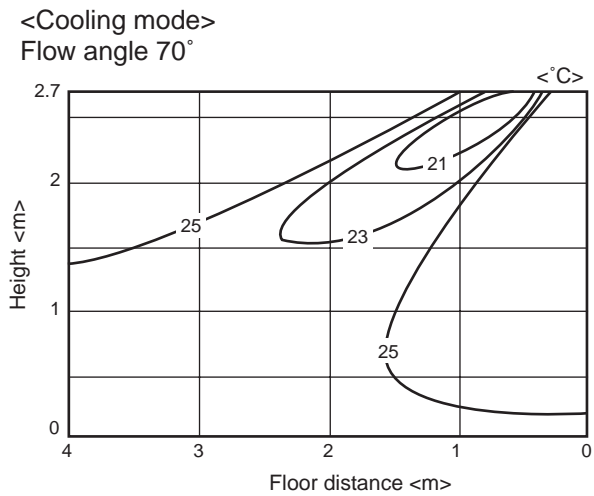
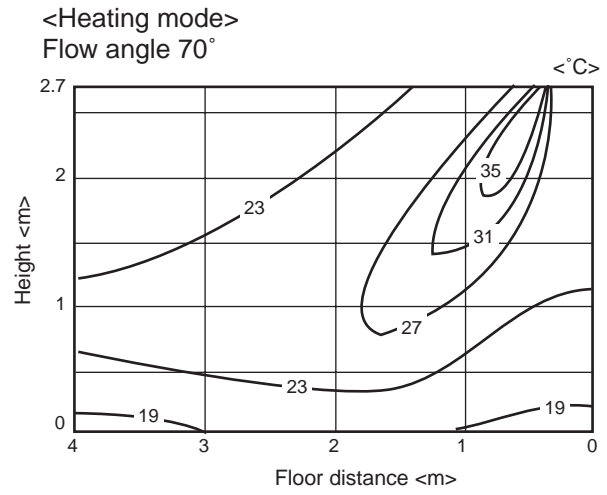
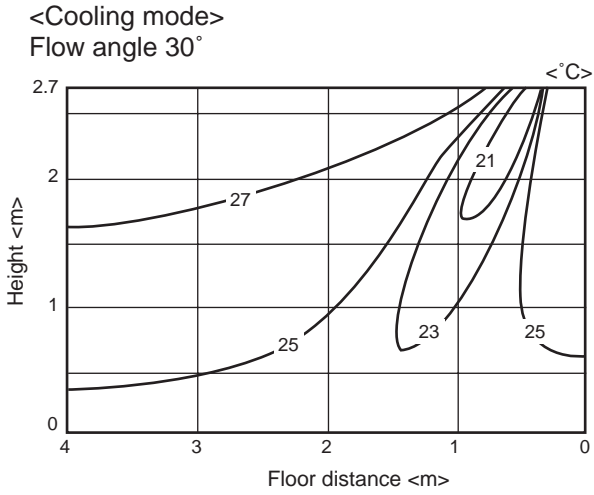

● Airflow distribution

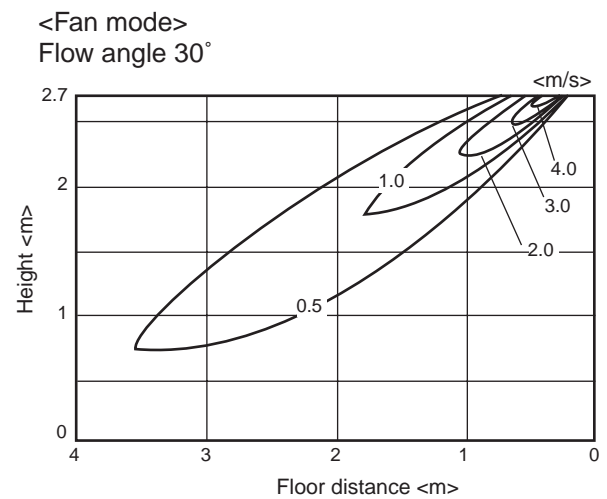
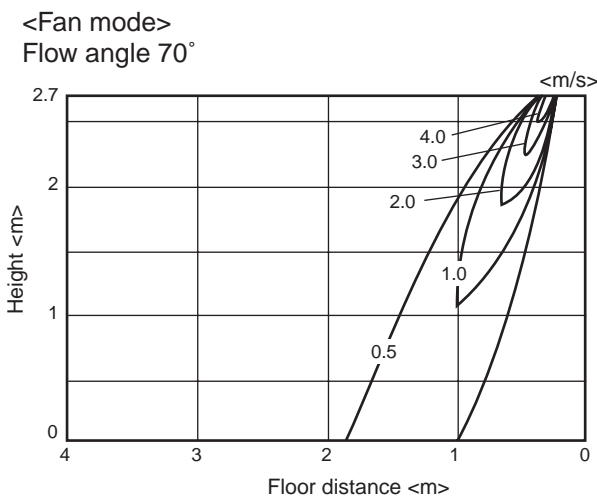

7. Options

● PLFY-P32/P40/P50/P63VKM-A

Description	Model
Decoration panel	PLP-25KB
Space panel	PAC-SE01AS-E
Wide panel	PAC-SE06WP-E
Air outlet shutter plate	PAC-SE14SP-E
High efficiency filter element	PAC-SE13KF-E (PAC-SE21TM-E is necessary to use this filter)
Multi-function casement (High efficiency filter casement) (Fresh air intake casement)	PAC-SE21TM-E

● PLFY-P80/P100/P125VAM-A

Description	Model
Air outlet shutter plate	PAC-SG06SP-E
High efficiency filter casement	PAC-SG01KF
Multi-function casement	PAC-SG03TM-E